

# AOM Specifications 声光调制器产品规格书

## STM0011-QL110-060-343

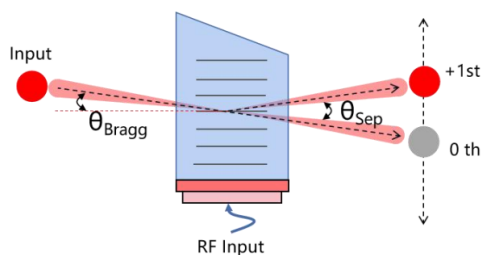

### 1. SPECIFICATIONS (规格)

Interaction material (介质材料)	Crystal quartz (石英)
Acoustic mode (声波模式)	Longitudinal (纵波)
Operating wavelength (工作波长)	343nm
Polarization (光偏振)	Linear, vertical to base (线偏振, 垂直于基座)
Transmission (透过率)	> 99%
Active aperture (有效孔径)	6.0mm
Center frequency (Fc) (中心频率)	110MHz
Diffraction efficiency (衍射效率)	> 85%
RF power (射频功率)	20 W (max)
Input Impedance (输入阻抗)	50Ω Nominal
VSWR (驻波比) @Fc	< 1.2:1
RF connector (射频接头)	BNC-F
Water flow rate (水流量)	> 0.2 L / minute
Cooling (散热方式)	Water-cooling (水冷散热)
Shell material (外壳材料)	Aluminum alloy 6063 (铝6063)
Water cooling channel material (水冷块材料)	Stainless steel 316 (不锈钢316)

### 2. PERFORMANCE vs. WAVELENGTH (性能 vs. 波长)

Wavelength (光波长) -nm	343
Bragg angle (布拉格角) -mrad	3.3
Separation angle (分离角) -mrad	6.6

### 3. ESTIMATED PERFORMANCE vs. BEAM DIAMETER (预估性能 vs. 光束直径)

Beam diameter (光束直径) -mm	1	3	6
Rise time (上升沿时间) -ns	113	339	678
Diffraction efficiency (衍射效率) @Fc	85%	85%	85%

#### 4. ORDERING CODES (编码规则)

	Ec	Active aperture	Wavelength
STM0001—	GLXXX	XXX	XXXX
27.12 MHz	027	040 4 mm	9400 9.4 um
40.68 MHz	041	060 6 mm	10600 10.6 um
80 MHz	080	080 8 mm	

#### 5. DIMENSIONS (外形尺寸-mm)

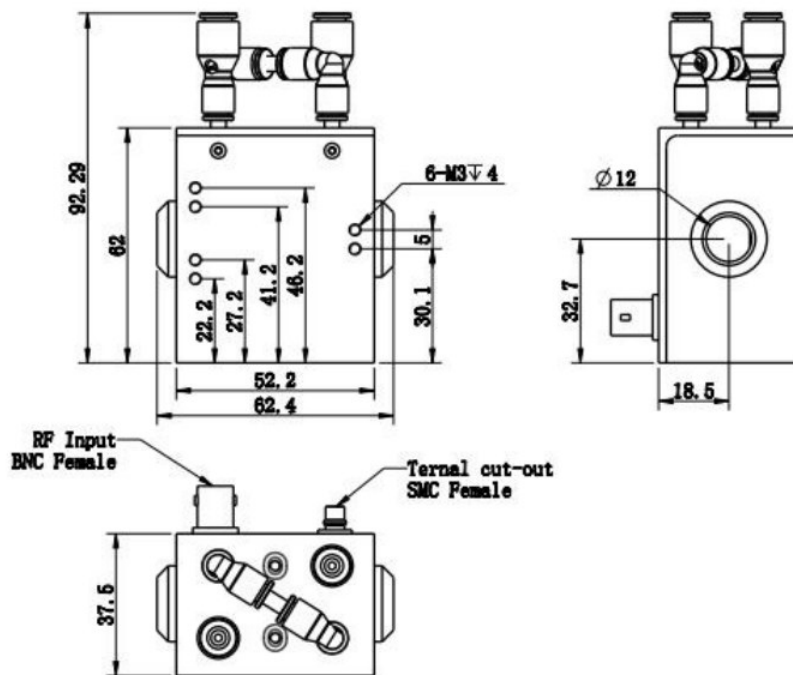

#### 6. SUGGESTED RF DRIVER ELECTRONICS (建议驱动型号)

RD1005-110-24-030-CA

#### 7. REVISION (版本)

Number (版本号)	Revisions date (修订日期)	Revision (修改项目)	Revision description (修订内容说明)
A	2022.8.3	New	/

**Quality Assured:** In house made, high damage threshold, Vacuum bonding, 100% Diffraction efficiency test & burn-in test.