

Single-Mode DFB CW QCL Laser

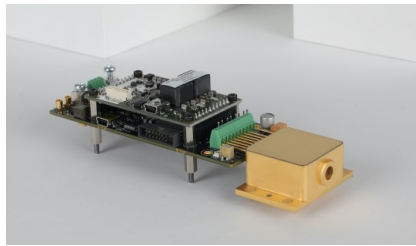
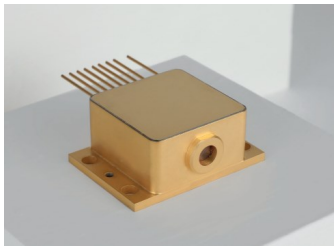

2023 V1

For customized projects please Contact us:

info@simtrum.com

Quantum Cascade Lasers from 10µm to 17µm – HHL packaging

These lasers are DFB Quantum Cascade lasers (QCL) that emit continuous wave (CW) infrared light at room temperature with wavelengths ranging from 10 microns to 17 microns. The lasers are mounted on a thermoelectric cooler inside a sealed High Heat Load (HHL) package integrating a collimation lens and a thermistor to readout the laser chip temperature.

Amazing pulsed-operation features

Pulsed operation is an attractive option for SIMTRUM. It means less electrical power consumption of the package, higher temperature operation, larger tunability, access to even longer wavelengths, smaller heatsink and easier integration in systems. A unique feature of the long wavelength SIMTRUM product is its very small spectral chirp during the pulse, typically $<0.04 \text{ cm}^{-1}/100\text{ns}$. It allows intrapulse spectroscopy without the need of high-speed detection or QCW spectroscopy without a degradation of the spectral resolution (down to 0.01 cm^{-1}) to be implemented. (SIMTRUM can provide a dedicated electronics for pulsed operation.)

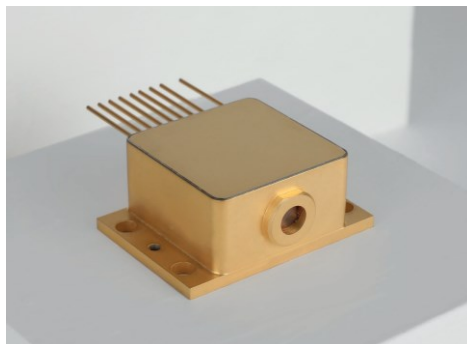

By controlling the chip's operating temperature through the Peltier element inside the laser's package, customers tune the emission wavelength without mode hopping while keeping a longitudinal single-mode operation.

For larger tuning range, pulsed operation is an attractive option because at these long wavelengths, the intrapulse linewidth broadening is relatively smaller than at shorter wavelengths.

The red curve indicates the maximum chip temperature as a function of the wavelength for CW lasers and the green curve indicates the maximum chip temperature as a function of the wavelength for the pulsed laser.

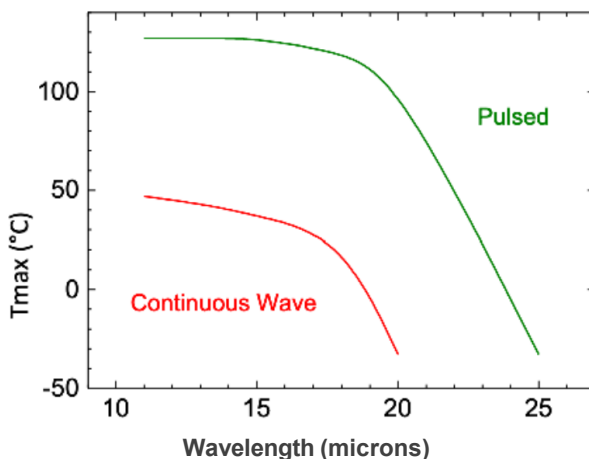

Specifications

Typical laser characteristics

Laser type	QCL single mode Distributed Feedback lasers (DFB) (1)
Mode of operation	CW or pulsed
Typical Optical Power	5-10mW typical for wavelength under 15 microns 1-5mW typical for wavelength above 15 microns Up to 20mW with a Fabry-Pérot laser (1)
Full accessible wavelength range	$\sim 3 \text{ cm}^{-1}$ typically
Continuous tuning range	$> 1 \text{ cm}^{-1}$ typically
Side mode suppression ratio	SMSR $> 25 \text{ dB}$
Linewidth (FWHM)	$< 100 \text{ Mhz}$ (free-running with suitable electronics for CW lasers)
Divergence	$< 10 \text{ mrad}$
Beam quality	TM00
Output beam diameter (window output)	Typically 4 mm
Polarization	Linear vertically polarized

(1): Fabry-Pérot lasers are also available. They offer larger output power (up to 20 mW), with broader emission spectrum.

Mechanical and electrical features

Packaging	Sealed inside a High-Heat Load (HHL) package
Operating temperature of the laser HHL casing	+10°C to +50°C(1)
Operating temperature of the QCL chip (for casing temperature of 20°C)	-10°C to +10°C(2)
Storage temperature	+10°C to +50°C
Built-in temperature sensor thermistor	Resistance @ 25°C: 10 kΩ 0/50 °C Beta value: $\beta = 3892 \text{ K}$

(1) Avoid water condensation

(2) The temperature of the QC-laser when operated is monitored by the built-in thermistor

Packaging Information

SIMTRUM can provide any wavelength in the 10-17 μm range and below are examples of gases that can be measured by spectroscopy at specific wavelengths.

Wavelength		Measurable gases
In microns units	In cm-1 units	
~ 11.3 μm	~ 885 cm-1	CH ₃ I Methyl Iodide
~ 11.8 μm	~ 850 cm-1	COCl ₂ Phosgene
~ 12.6 μm	~ 795 cm-1	p-Xylene
~ 13 μm	~ 769 cm-1	m-Xylene
~ 13.5 μm	~ 741 cm-1	o-Xylene
~ 13.7 μm	~ 729 cm-1	Toluene
~ 14 μm	~ 713 cm-1	HCN Hydrogen cyanide
~ 14.3 μm	~ 697 cm-1	Ethylbenzene
~ 14.4 μm	~ 694 cm-1	Toluene
~ 14.8 μm	~ 673 cm-1	Benzene
~ 15.9 μm	~ 628 cm-1	UF ₆ Uranium hexafluoride
~ 16 μm	~ 624 cm-1	Neptunium NpF ₆
~ 16.1 μm	~ 619 cm-1	Plutonium PuF ₆
~ 17.2 μm	~ 581 cm-1	Nitrous oxide N ₂ O

Specifications

Data About the built-in TEC

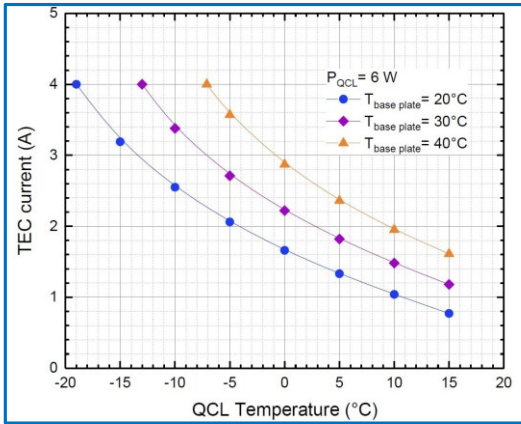

1

TEC current consumption as a function of the wanted QCL chip temperature for different base plate temperatures and for a QCL thermal load of 6W.

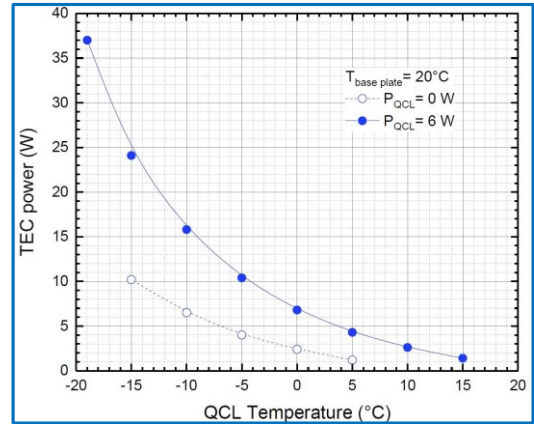

3

Power consumption of the built-in TEC1 as a function of the QCL chip temperature of +20°C, with and without a thermal load in the QCL.

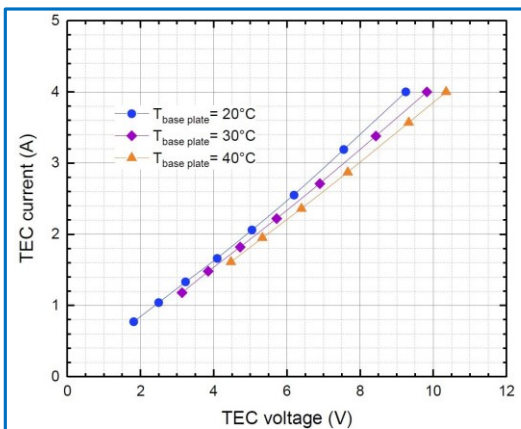

2

Current-voltage characteristics of the built-in TEC for different temperatures of the base plate.

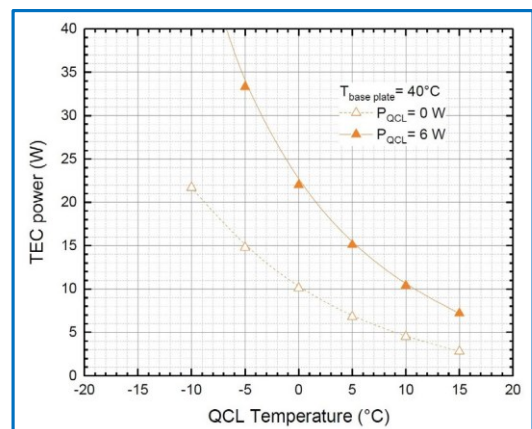

4

Power consumption of the built-in TEC1 as a function of the QCL chip temperature for a base plate temperature of +40°C, with and without a thermal load in the QCL.

Packaging Information

HHL Package View

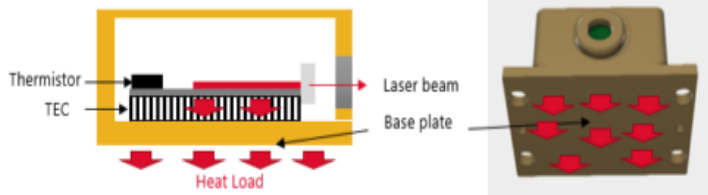
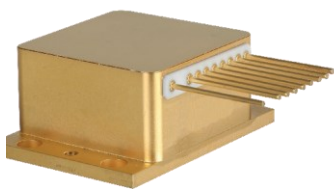

HHL package diagram showing the built-in thermistor that monitors the laser chip temperature and the base plate that dissipates the heat generated by the laser and the TEC.

Electrical connections (pinout)

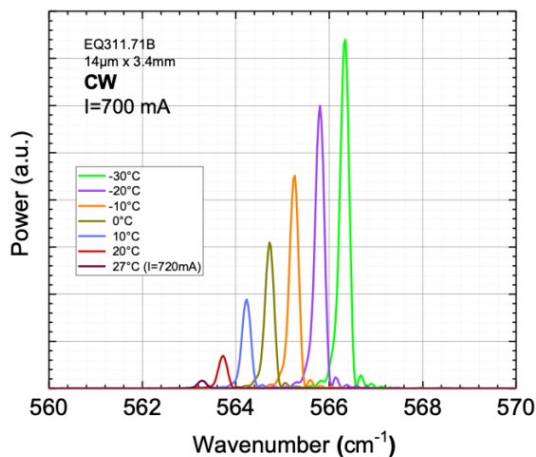
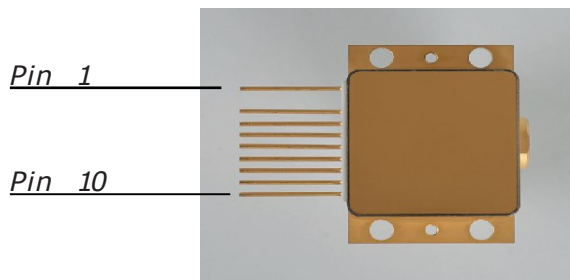

Example of emission spectra as a function of the chip temperature for a QCL emitting at the wavelength of 17.7 μm . These DFB lasers are single mode with a side mode suppression ratio larger than 25dB.

1	TEC(-)
2	No pin
3	Not connected
4	Thermistor(10k Ω)
5	Thermistor(10k Ω)
6	QCL(+)
7	QCL(-)
8	Not connected
9	Not connected
10	TEC(+)

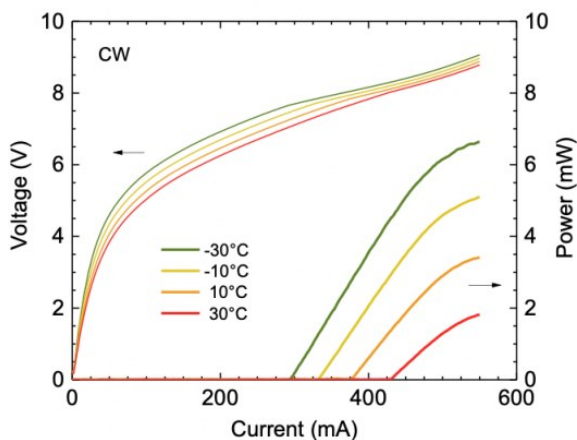

Typical output characteristics of a DFB QCL emitting at 13.5 μm .

System Configurations

Customers can purchase different laser systems depending on the needs

Laser + Driver Modules

For clients who want to integrate the laser in a product, SIMTRUM provides the Laser + Driver module controllable by Windows Software and made of a PCB driver connected to the HHL-packaged laser.

The driver takes care of temperature and current control, laser safety and modulation is possible, both external with a TTL signal or with a Windows software.

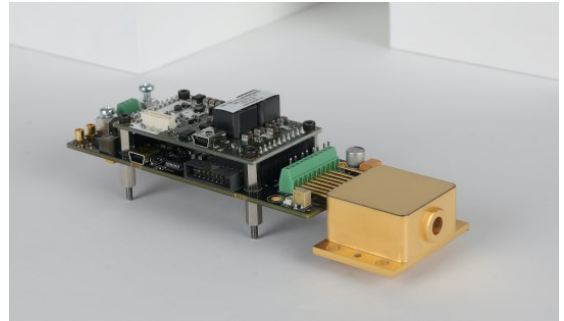

Benefits

- Generates pulse widths down to 10ns
- Both external (TTL) and internal modulation with Windows software possible
- Driver includes both temperature and current control and onboard firmware safeguards the laser
- Controllable both with user friendly Windows software supplied or with Modbus communications over RS485
- Several systems can be controlled and synchronized for power combination
- Designed for integration into systems

Features

Functionalities

Laser safety, Laser driver (ON/OFF), Laser temperature and TEC control, frequency modulation, external TTL

Physical interface

USB, RS485

Protocol

Modbus

Input power

24V DC

Dimension

4.45cm x 11cm x 2.5cm

Weight

190g (HHL 120g and PCB 70g)

Operational temp

-20°C to +30°C @base plate. This working environmental temperature must in any case be above dew point to avoid water condensation.

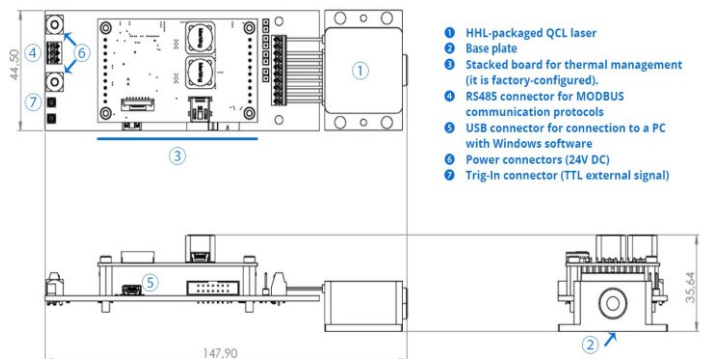

System Configurations

Customers can purchase different laser systems depending on the needs

Plug-and-play desktop turnkey system

For lab development purposes, SIMTRUM provides a plug-and-play desktop turnkey system that takes care of everything like temperature and current control, air cooling and laser safety and comes with a user-friendly Windows software to operate the laser and modulate its power (external TTL modulation being also possible). The turnkey system can control two laser heads at the same time and can be fitted with red beam alignment lasers to make alignment easier in the lab.



Benefits

- Supports high-power lasers and can operate lasers >1W of power
- Fast: can modulate adown to 10 nanoseconds of pulse width
- Can operate QCW lasers
- Plug-and-play system that takes care of everything (air cooling, driver, temperature management..)
- Keep your driver for future extra laser heads – no need to purchase a new driver
- Red beam laser helps you align your setup

Features

Functionalities

Laser safety, Laser driver (ON/OFF), Laser temperature and TEC control, frequency modulation, duty cycle, external TTL

Physical interface

USB interface for PC connection (USB cable supplied)

TTL trig IN connector for TTL external signal

TTL trig OUT connector for synchronization

Option: Extra red laser beam for alignment help (typically 2-3mrad of pointing difference between the red laser beam and the infra-red beam)

Software

A user-friendly Windows software is supplied

Input power

24V DC (an AC/DC power transformer is supplied)

Dimension

Laser head: 20cm x 15cm x 6cm

Driver: 25cm x 15cm x 6cm

Weight

925g

Operational temp

+10°C to +30°C of ambient temperature

Laser head cooling

Air cooled

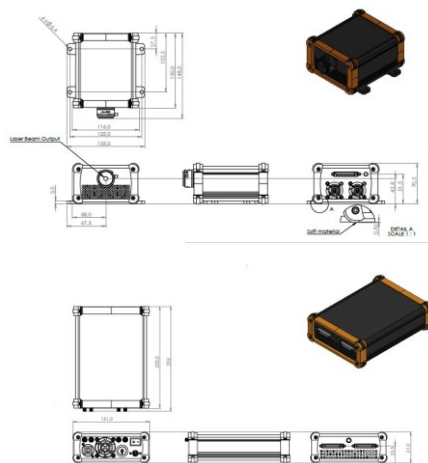

System Configurations

Parameters	HHL Package	Laser + Driver Module	Turnkey System
Collimating Lens Inside the Package	√	√	√
Built-in Thermistor and Thermoelectric Cooler (TEC) Inside the Package	√	√	√
Sealed Atmosphere Package	√	√	√
Plug and Play			√
Multiple Laser Heads			√
Red Beam Alignment			√
Air Cooling			√
Manual Shutter & Safety Key			√
User-friendly Software		√	√
Temperature Control of QCL Chip		√	√
MODBUS Control		√	
Software or TTL Power Modulation		√	√
Modulation Down to 10ns of Pulse-width		√	√